

NO. E1AX-2091

ISSUED: JAN. 1999

REVISED: DEC. 2011



HOSHIZAKI
SELF-CONTAINED CUBER

MODEL **IM-25CLE**
IM-25CLE-25
IM-30CLE
IM-30CLE-25

PARTS LIST

[HE , GENERAL (50Hz) , RINNAI , OCEANIA , AUSTRALIA , HSP , GRAM , CHINA]

J-1 DEC. 1998	D-2 OCT. 2004
K-0 DEC. 1999	E-0 DEC. 2004
K-1 FEB. 2000	E-1 APR. 2005
K-2 APR. 2000	F-0 DEC. 2005
A-05 DEC. 2000	G-0 JAN. 2007
A-1 JUN. 2001	G-1 MAY. 2007
B-0 DEC. 2001	H-1 JAN. 2008
C-0 DEC. 2002	H-2 AUG. 2008
C-1 MAR. 2003	U-0 JAN. 2009
D-0 DEC. 2003	V-0 JAN. 2010
D-1 JUL. 2004	A-01, L-0 JAN. 2011

MATERIAL ABBREVIATIONS

ALUMINUM

AL = Aluminum

COPPER

CU = Copper

PLASTIC

ABS = Acrylonitrile -butadiene - styrene
AC = Polyacetal
EVA = Ethylene vinyl acetate
PA = Polyamide = Nylon
PC = Polycarbonate
PE = Polyethylene
PES = Polyester
PETP = Polyethylene terephthalate = Tetlon
PP = Polypropylene
PS = Polystyrene
PTFE = Polytetrafluoroethylene = Teflon
PUR = Polyurethane
PVC = Polyvinyl chloride

RUBBER

VN = Vinyl Nitrile
EPDM = EP rubber
NBR = Nitrile butadiene rubber
NR = Natural rubber
NP = Neoprene
SI.R = Silicone rubber
SY.R = Synthetic rubber
EPH = Epichlorohydrin

STEEL

GS = Galvanized steel
SS = Stainless steel
PS = Plated steel
PAS = Primed steel

AUXILIARY CODE

K-0

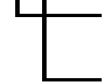

Designates the year. "K" indicates the year 2000. Years progress or regress in alphabetical order. "J" is 1999, "L" is 2001, "M" is 2002, and so on. The letters "I" and "O" were skipped.

Designates significant part changes within the same year. Base is 0 and this number advances for each change.

Example: P-1



"P" indicates 2004.

"1" indicates the first significant part change for 2004.

MARKS LOCATED UNDER THE AUXILIARY CODE

- = Part deleted.
- x = Part deleted and replaced by "o" part.
- o = New part in place of "x" part.

FASTENER ABBREVIATION LIST

ST	=	Phillips Truss Head Machine Screw
SP	=	Phillips Pan Head Machine Screw
SF	=	Phillips Flat Head Machine Screw
SS	=	Phillips Pan Head Machine Screw with Split Lock Washer
SW	=	Phillips Pan Head Machine Screw with Split Lock Washer and Flat Washer
T1	=	Phillips Truss Head Tapping Screw (Correspond to Type A)
T2	=	Phillips Truss Head Tapping Screw (Correspond to Type B)
T3	=	Phillips Truss Head Tapping Screw (Correspond to Type C)
FT	=	Phillips Truss Head Tapping Screw (Special)
BH	=	Hexagon Head Bolt
BC	=	Socket Head Cap Screw
BS	=	Hexagon Bolt with Split Washer
BW	=	Hexagon Bolt with Split Washer and Flat Washer
BF	=	Hexagon Flange Bolt
BR	=	Cross-Recessed Hexagon Head Bolt
BRW	=	Cross-Recessed Hexagon Head Bolt with Split Lock Washer and Flat Washer
WL	=	Split Lock Washer
WT	=	External Tooth Washer
WF	=	Flat Washer
WS	=	Spring Washer
NH	=	Hexagon Nut
NF	=	Hexagon Flange Nut
NC	=	Hexagon Cap Nut
NS	=	Square Nut
NW	=	Wing Nut

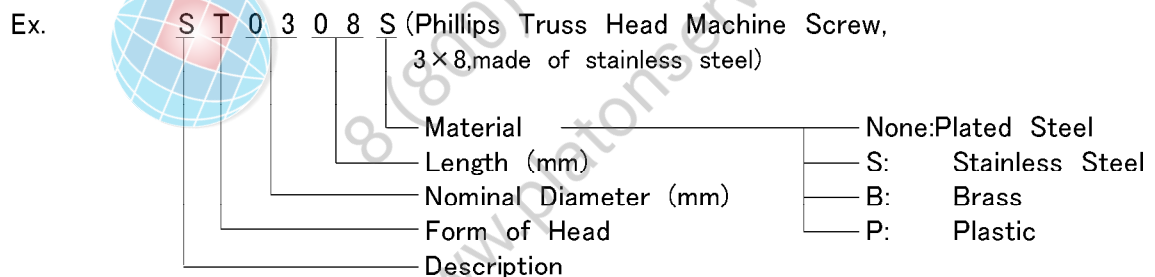

(Note) Second character is numerical except the list.
Ex: S1,S2,B3 etc.

And abbreviations and names are shown under the illustration.

IM-25CLE, -25
IM-30CLE, -25

A. ICE CUBER ASSY

(A-05)(A-1) (B-0) (C-0)
(J-1) (K-0) (K-1) (K-2)

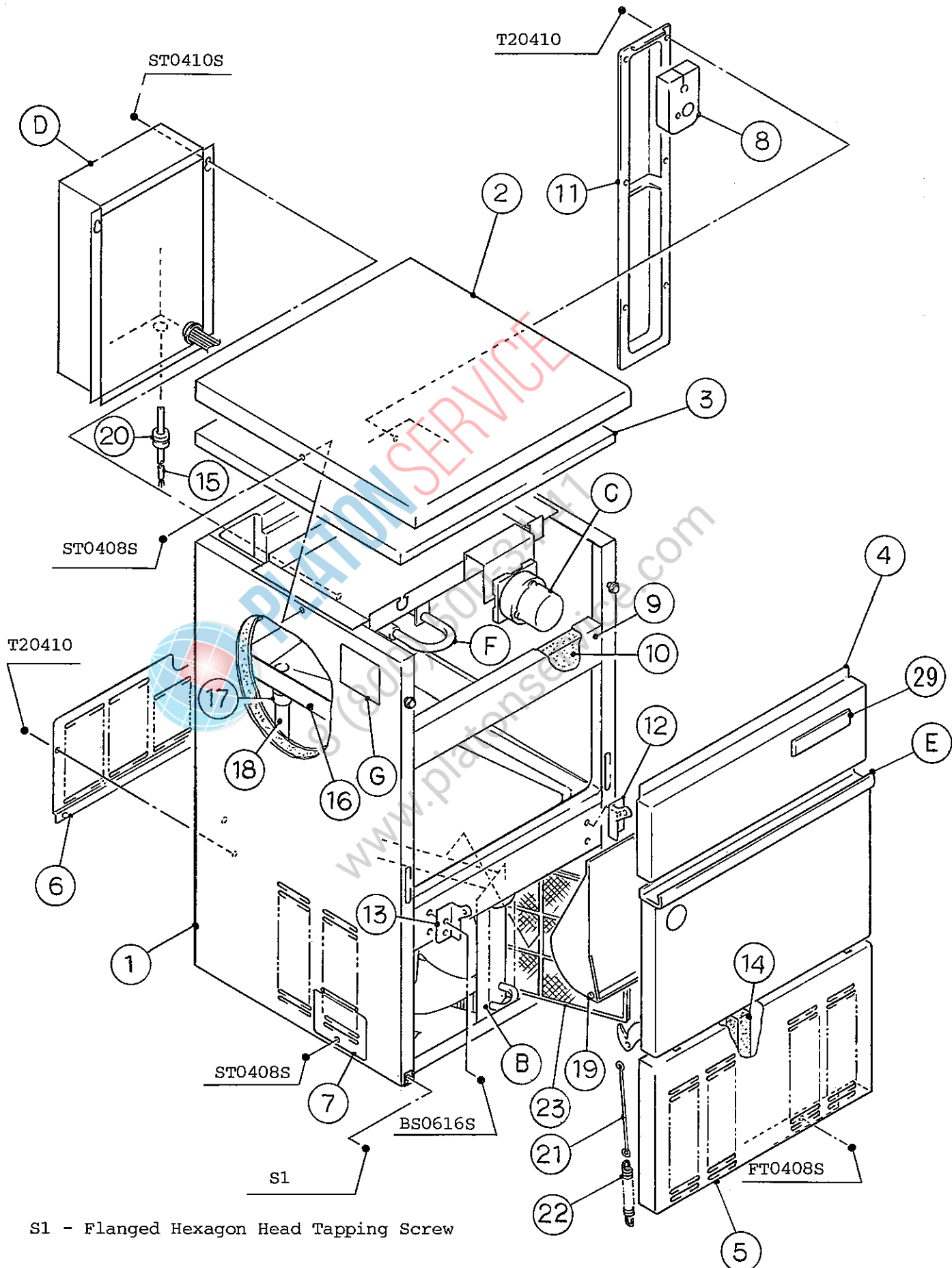

S1 - Flanged Hexagon Head Tapping Screw

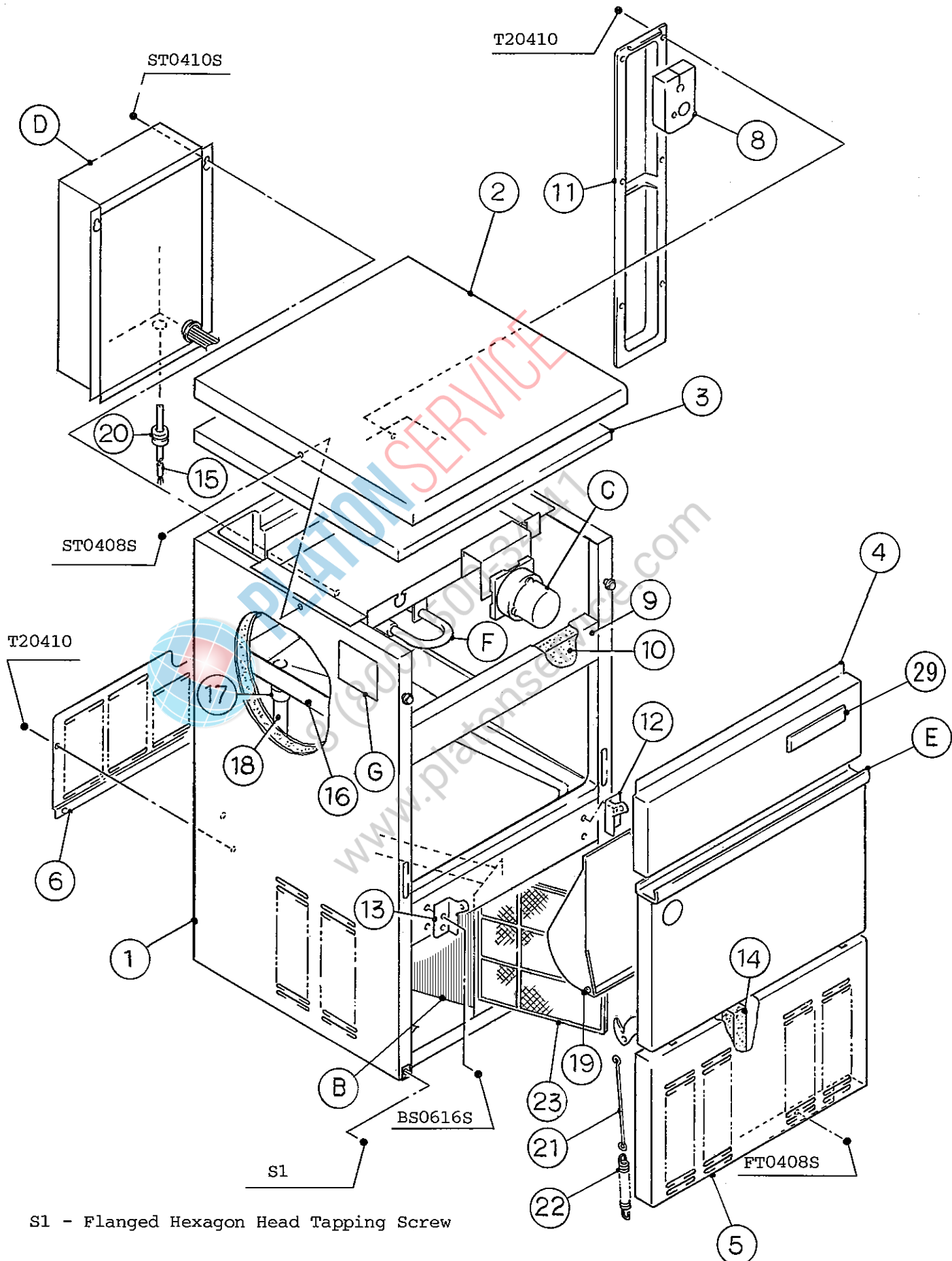

S1 - Flanged Hexagon Head Tapping Screw

IM-25CLE, -25
IM-30CLE, -25

A. ICE CUBER ASSY

(F-0) to (H-1)
(D-1) (D-2) (E-0) (E-1)

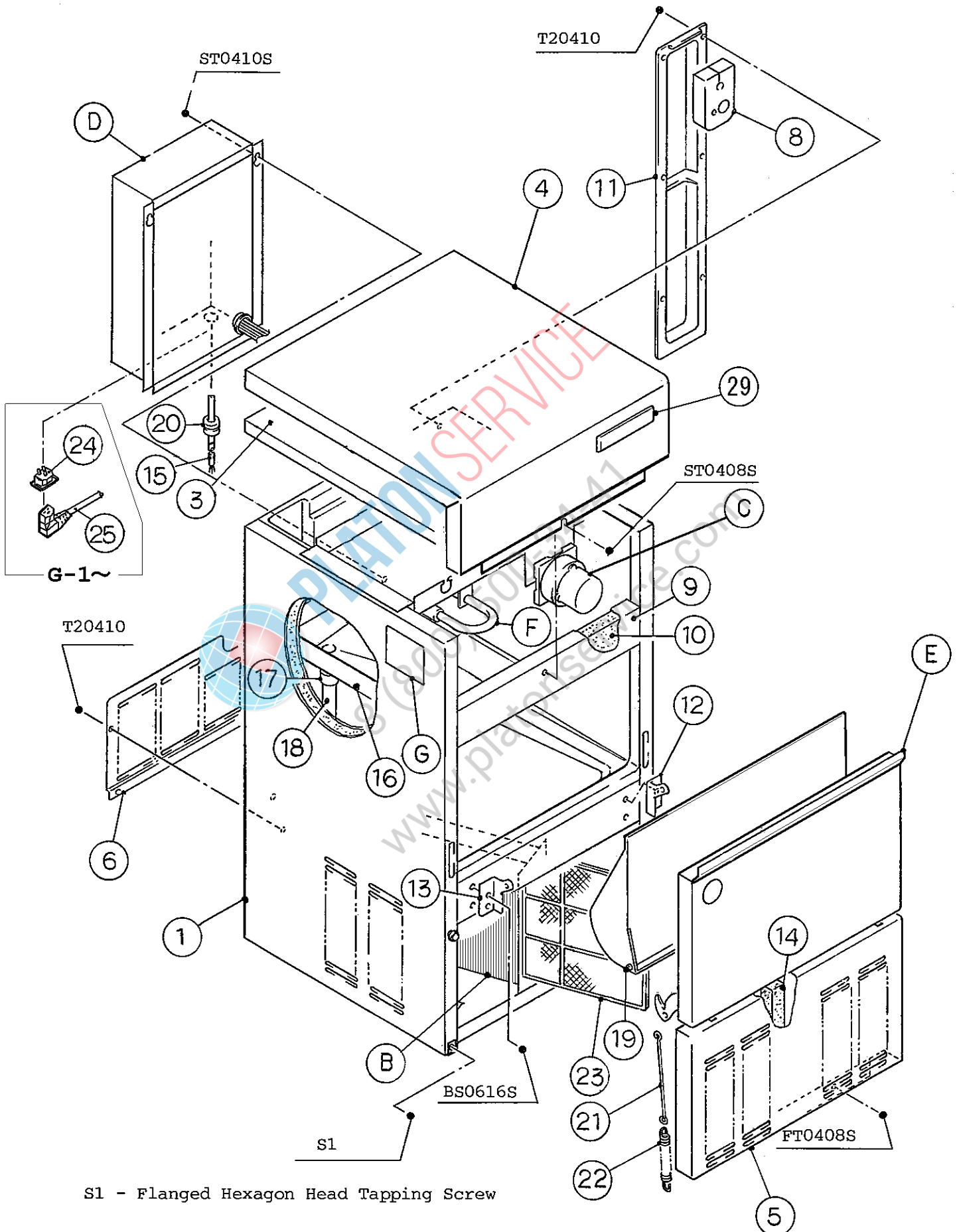

S1 - Flanged Hexagon Head Tapping Screw

IM-25CLE, -25
IM-30CLE, -25

A. ICE CUBER ASSY

(H-2) and later

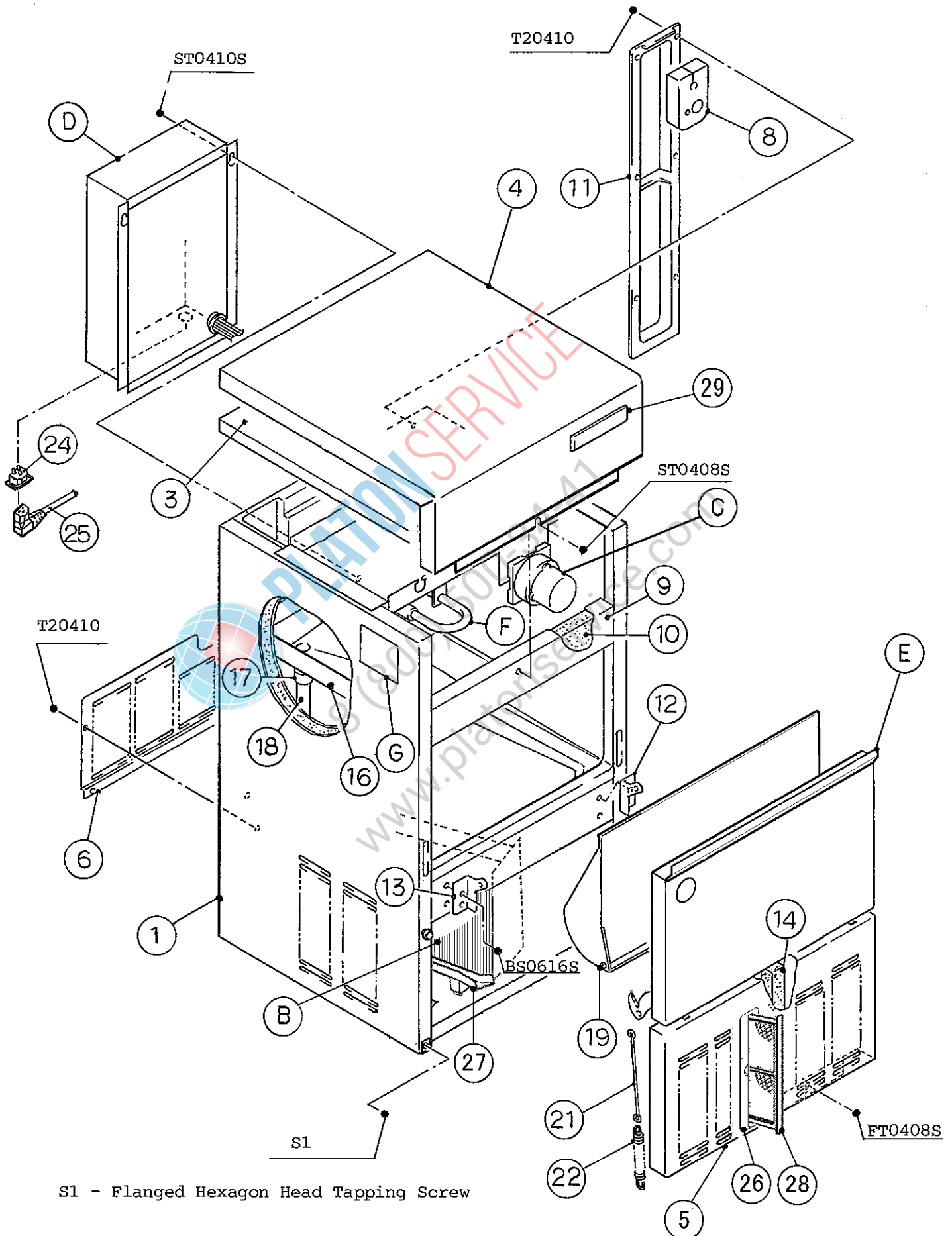

S1 - Flanged Hexagon Head Tapping Screw

HE, GENERAL, RINNAI, OCEANIA, AUSTRALIA, HSP

MODEL : IM-25CLE, IM-25CLE-25 IM-30CLE, IM-30CLE-25 TITLE : A. ICE CUBER ASSY							
INDEX NO.	DESCRIPTION	MATERIAL OR MODEL NUMBER	PART NUMBER	REQ'D NUMBER			
				J-1 K-0	K-1	K-2 A-05	A-1 B-0 C-0
B	REFRIGERATION ASSY	(IM-25CLE) (IM-30CLE)	1H1921A01	1	1	—	
			1H2147A01			1	1
			1H2820A01				
	REFRIGERATION ASSY	(IM-25CLE-25) (IM-30CLE-25)	-	1	1	1	1
C	ICEMAKING MECHANISM ASSY	(IM-25CLE) (IM-30CLE)	1H0272A04	1	—		
			1H0272A11		1	1	—
			1H0272A12				1
	ICEMAKING MECHANISM ASSY	(IM-25CLE-25) (IM-30CLE-25)	-	1	1	1	1
D	CONTROL BOX ASSY	-	2H3977A01	1	—		
			2H3977A02		1	1	1
			2H3977A03				
			2H6749A01				
			2H6749A02				
E	DOOR ASSY	-	3H5756A03	1	1	1	1
			3X7332A01				
			3Y2892A01				
F	WATER CIRCUIT ASSY	-	3H9599A02	1	1	—	
			3H9599A03			1	1
G	LABEL LOCATION	-	3X2571A01	1	1	1	1
			3X2571A02				
1	UNIT FRAME	S.S, G.S	1H1920G01	1	1	—	
		S.S, G.S	1H2045G01			1	1
		S.S, G.S	1H2045G02				
		S.S, G.S	1H2045G03				
2	TOP PANEL	S.S	3H9606-01	1	1	1	1
3	INSULATION - TOP PANEL	PE	2H0655-01	1	1	1	1
4	FRONT PANEL (UPPER)	S.S	3H8109G01	1	1	1	1
		S.S	3X7334G01				
5	FRONT PANEL (LOWER)	S.S	3X2592-01	1	1	—	
		S.S	3X3184-01			1	1
		S.S	3X7278-01				

HE, GENERAL, RINNAI, OCEANIA, AUSTRALIA, HSP

MODEL : IM-25CLE, IM-25CLE-25 IM-30CLE, IM-30CLE-25 TITLE : A. ICE CUBER ASSY							
INDEX NO.	DESCRIPTION	MATERIAL OR MODEL NUMBER	PART NUMBER	REQ'D NUMBER			
				C-1 D-0	D-1	D-2 E-0	E-1 F-0 G-0
B	REFRIGERATION ASSY	(IM-25CLE) (IM-30CLE)	-				
			1H2147A01	-			
			1H2820A01	1	1	1	1
	REFRIGERATION ASSY	(IM-25CLE-25) (IM-30CLE-25)	-	1	1	1	1
C	ICEMAKING MECHANISM ASSY	(IM-25CLE) (IM-30CLE)	-				
			1H0272A11				
			1H0272A12	1	1	1	1
	ICEMAKING MECHANISM ASSY	(IM-25CLE-25) (IM-30CLE-25)	-	1	1	1	1
D	CONTROL BOX ASSY	-	-				
			2H3977A02	1	1	-	
			2H3977A03			1	-
			2H6749A01				1
			2H6749A02				
E	DOOR ASSY	-	3H5756A03	1	-		
			3X7332A01		1	1	1
			3Y2892A01				
F	WATER CIRCUIT ASSY	-	-				
			3H9599A03	1	1	1	1
G	LABEL LOCATION	-	3X2571A01	1	1	1	-
			3X2571A02				1
1	UNIT FRAME	S.S, G.S	-				
			1H2045G01	-			
			1H2045G02	1	-		
		S.S, G.S	1H2045G03		1	1	1
2	TOP PANEL	S.S	3H9606-01	1	x		
3	INSULATION - TOP PANEL	PE	2H0655-01	1	1	1	1
4	FRONT PANEL (UPPER)	S.S	3H8109G01	1	-		
		S.S	3X7334G01		1	1	1
5	FRONT PANEL (LOWER)	S.S	3X3184-01	-			
		S.S	3X7278-01	1	-		
		S.S	3X7328-01		1	1	1

HE, GENERAL, RINNAI, OCEANIA, AUSTRALIA, HSP,GRAM,CHINA

MODEL : IM-25CLE, IM-25CLE-25 IM-30CLE, IM-30CLE-25 TITLE : A. ICE CUBER ASSY							
INDEX NO.	DESCRIPTION	MATERIAL OR MODEL NUMBER	PART NUMBER	REQ'D NUMBER			
				G-1	H-1	H-2,U-0 V-0,A-01 L-0	
B	REFRIGERATION ASSY	(IM-25CLE,30CLE) (HE,GENERAL, RINNAI,OCEANIA, AUSTRALIA,HSP, CHINA)	1H2820A01	1	1	-	
			1H2820A02			1	
		(GRAM)	1H2820001			1	
	REFRIGERATION ASSY	(IM-25CLE-25) (IM-30CLE-25)	-	1	1	1	
C	ICEMAKING MECHANISM ASSY	(IM-25CLE) (IM-30CLE)	1H0272A12	1	1	1	
	ICEMAKING MECHANISM ASSY	(IM-25CLE-25) (IM-30CLE-25)	-	1	1	1	
D	CONTROL BOX ASSY	-	2H6749A01				
		-	2H6749A02	1	1	1	
E	DOOR ASSY	(HE,GENERAL, RINNAI,OCEANIA, AUSTRALIA,HSP, CHINA)	3X7332A01	1	-		
			3Y2892A01		1	1	
		(GRAM)	3Y2892001				
F	WATER CIRCUIT ASSY	-	3H9599A03	1	1	1	
G	LABEL LOCATION	-	3X2571A02	1	1	1	
1	UNIT FRAME	S.S, G.S	1H2045G03	1	1	1	
2	-	-	-				
3	INSULATION - TOP PANEL	PE	2H0655-01	1	1	1	
4	FRONT PANEL (UPPER)	(HE,GENERAL, RINNAI,OCEANIA, AUSTRALIA,HSP, CHINA)	3X7334G01	1	1	1	
		(GRAM)	3X7334G04			1	
5	FRONT PANEL (LOWER)	S.S	3X7328-01	1	1	-	
		S.S	3Y3673G01			1	
6	REAR PANEL	G.S	4X7301-01	1	1	1	
7	-	-	-				
8	INSULATION	PE	4X5295-02	1	1	1	
9	FRONT FRAME	S.S	3H1678-10	1	1	1	
10	INSULATION - FRONT FRAME	PE	4H2317-01	1	1	1	
11	PIPE COVER	G.S	3H0172-02	1	1	1	
12	HINGE (RIGHT)	S.S	4H2583-01	1	1	1	

HE, GENERAL, RINNAI, OCEANIA, AUSTRALIA, HSP

MODEL : IM-25CLE, IM-25CLE-25 IM-30CLE, IM-30CLE-25 TITLE : A. ICE CUBER ASSY							
INDEX NO.	DESCRIPTION	MATERIAL OR MODEL NUMBER	PART NUMBER	REQ'D NUMBER			
				J-1 K-0	K-1	K-2 A-05	A-1 B-0 C-0
6	REAR PANEL	G.S	4X6673-01	1	1	—	
		G.S	4X7301-01			1	1
7	COVER - SIDE PANEL	S.S	4X6807-01	1	x		
8	INSULATION	PE	4X5295-02	1	1	1	1
9	FRONT FRAME	S.S	3H1678-10	1	1	1	1
10	INSULATION - FRONT FRAME	PE	4H2317-01	1	1	1	1
11	PIPE COVER	G.S	3H0172-02	1	1	1	1
12	HINGE (RIGHT)	S.S	4H2583-01	1	1	1	1
13	HINGE (LEFT)	S.S	4H2584-01	1	1	1	1
14	SEAL (A)	PE	4H4359-02	1	1	—	
		PE	4H4359-04			1	1
		PE	4Y0913-01				
15	POWER SUPPLY CORD (CONTINENTAL)	(HE)	452263-01	1	1	1	1
	POWER SUPPLY CORD (WITH UK PLUG)	(HE) (GENERAL) (HSP)	4X3521G01	1	1	1	1
	POWER SUPPLY CORD	(RINNAI) (OCEANIA) (AUSTRALIA)	458139-01	1	1	1	1
16	DRAIN PAN	ABS	2H1442-01	1	1	1	1
17	DRAIN TUBE	SI	4H2585-01	1	1	1	1
18	DRAIN PIPE	ABS	4H1141-04	1	1	1	1
19	SLOPE	ABS	3H3628-01	1	1	1	1
20	BUSHING	CEE SR-6P-10	448949-01	1	1	1	1
21	HOOK	S.S	404060-08	1	1	1	1
22	SPRING	ZINC COATED PIANO WIRE	4H0491-01	1	1	1	1
23	AIR FILTER	PE	208284G01	1	1	1	1
29	EMBLEM-HE	(HE)	356509-01	1	1	1	1

HE, GENERAL, RINNAI, OCEANIA, AUSTRALIA, HSP

MODEL : IM-25CLE, IM-25CLE-25 IM-30CLE, IM-30CLE-25 TITLE : A. ICE CUBER ASSY							
INDEX NO.	DESCRIPTION	MATERIAL OR MODEL NUMBER	PART NUMBER	REQ'D NUMBER			
				C-1 D-0	D-1	D-2 E-0	E-1 F-0 G-0
6	REAR PANEL	-	-				
		G.S	4X7301-01	1	1	1	1
7	-	-	-				
8	INSULATION	PE	4X5295-02	1	1	1	1
9	FRONT FRAME	S.S	3H1678-10	1	1	1	1
10	INSULATION - FRONT FRAME	PE	4H2317-01	1	1	1	1
11	PIPE COVER	G.S	3H0172-02	1	1	1	1
12	HINGE (RIGHT)	S.S	4H2583-01	1	1	1	1
13	HINGE (LEFT)	S.S	4H2584-01	1	1	1	1
14	SEAL (A)	-	-				
		PE	4H4359-04				
15	POWER SUPPLY CORD (CONTINENTAL)	(HE)	452263-01	1	1	1	1
	POWER SUPPLY CORD (WITH UK PLUG)	(HE) (GENERAL) (HSP)	4X3521G01	1	1	1	1
	POWER SUPPLY CORD	(RINNAI) (OCEANIA) (AUSTRALIA)	458139-01	1	1	1	1
16	DRAIN PAN	ABS	2H1442-01	1	1	1	1
17	DRAIN TUBE	SI	4H2585-01	1	1	1	1
18	DRAIN PIPE	ABS	4H1141-04	1	1	1	1
19	SLOPE	ABS	3H3628-01	1	1	1	1
20	BUSHING	CEE SR-6P-10	448949-01	1	1	1	1
21	HOOK	S.S	404060-08	1	1	1	1
22	SPRING	ZINC COATED PIANO WIRE	4H0491-01	1	1	1	1
23	AIR FILTER	PE	208284G01	1	1	1	1
29	EMBLEM-HE	(HE)	356509-01	1	1	1	1

HE, GENERAL, RINNAI, OCEANIA, AUSTRALIA, HSP,GRAM,CHINA

MODEL : IM-25CLE, IM-25CLE-25 IM-30CLE, IM-30CLE-25 TITLE : A. ICE CUBER ASSY							
INDEX NO.	DESCRIPTION	MATERIAL OR MODEL NUMBER	PART NUMBER	REQ'D NUMBER			
				G-1	H-1	H-2,U-0 V-0,A-01 L-0	
13	HINGE (LEFT)	S.S	4H2584-01	1	1	1	
14	SEAL (A)	PE	4Y0913-01	1	1	1	
15	POWER SUPPLY CORD (CONTINENTAL)	(HE)	452263-01	x			
	POWER SUPPLY CORD (WITH UK PLUG)	(HE) (GENERAL) (HSP)	4X3521G01	x			
	POWER SUPPLY CORD	(RINNAI) (OCEANIA) (AUSTRALIA)	458139-01	x			
16	DRAIN PAN	ABS	2H1442-01	1	1	1	
17	DRAIN TUBE	SI	4H2585-01	1	1	1	
18	DRAIN PIPE	ABS	4H1141-04	1	1	1	
19	SLOPE	ABS	3H3628-01	1	1	1	
20	BUSHING	CEE SR-6P-10	448949-01	x			
21	HOOK	S.S	404060-08	1	1	1	
22	SPRING	ZINC COATED PIANO WIRE	4H0491-01	1	1	1	
23	AIR FILTER	PE	208284G01	1	1	x	
24	CONNECTOR	-	P00245-01	1	1	1	
25	POWER CORD	(CONTINENTAL)	P00240-01	1	1	1	
	POWER CORD (WITH UK PLUG)	(UK)	P00241-01	1	1	1	
	POWER CORD	(AUSTRALIA)	P00242-01	1	1	1	
	POWER CORD	(CHINA)	P01960-01			1	
26	FILTER-GUIDE		2H9010P01			1	
27	FILTER-RAIL		3Y3497P01			1	
28	FILTER		3Y3496G01			1	
29	EMBLEM-HE	(HE) (CHINA)	356509-01	1	1	1	
	EMBLEM-GRAM	(GRAM)	4Y6123L01			1	

IM-25CLE, -25
IM-30CLE, -25

(A-05)(A-1) (B-0) (C-0)
B. REFRIGERATION ASSY (J-1) (K-0) (K-1) (K-2)

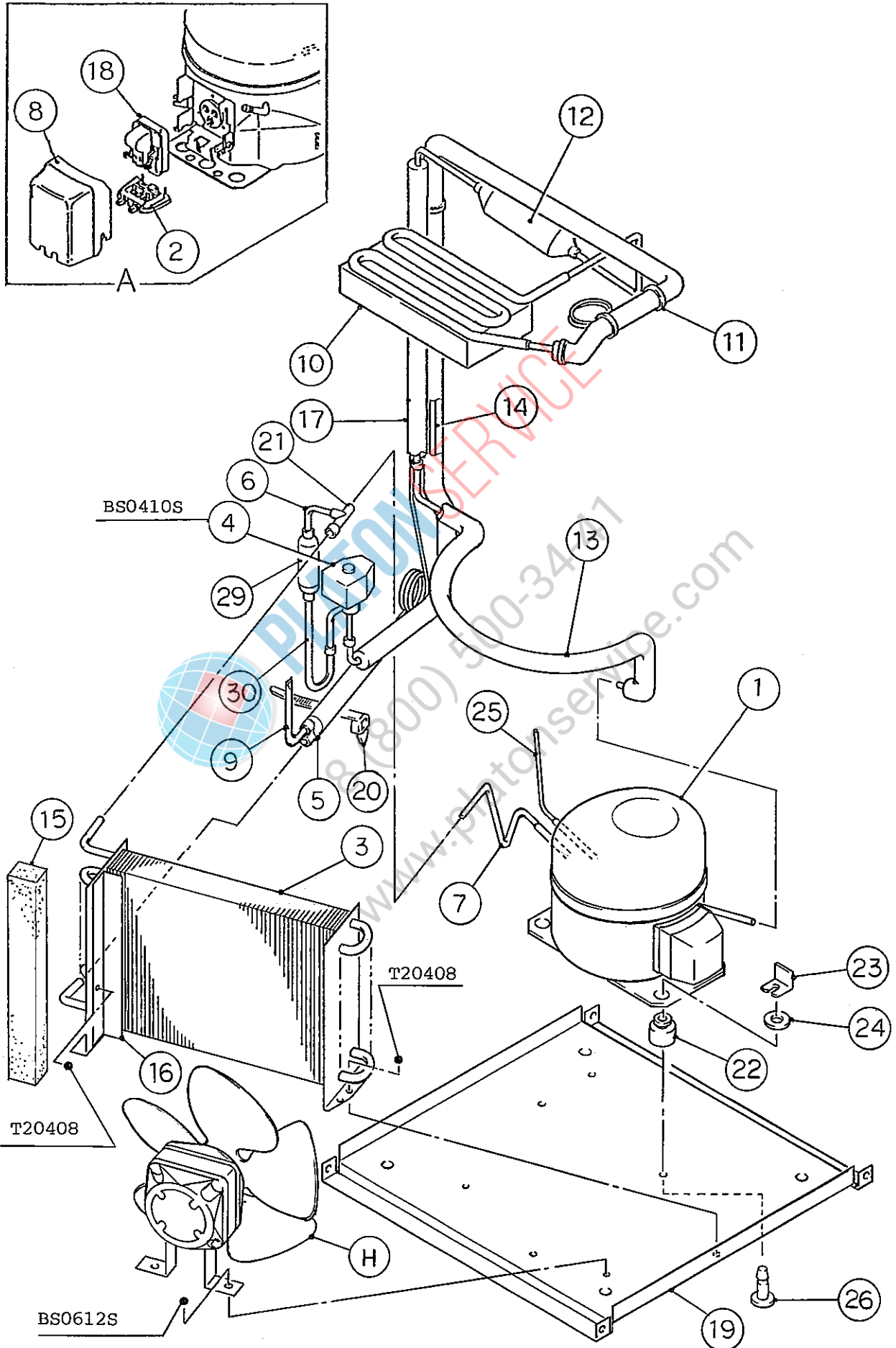

IM-25CLE, -25
IM-30CLE, -25

(E-0) (E-1) and later
B. REFRIGERATION ASSY (C-1) (D-0) (D-1) (D-2)

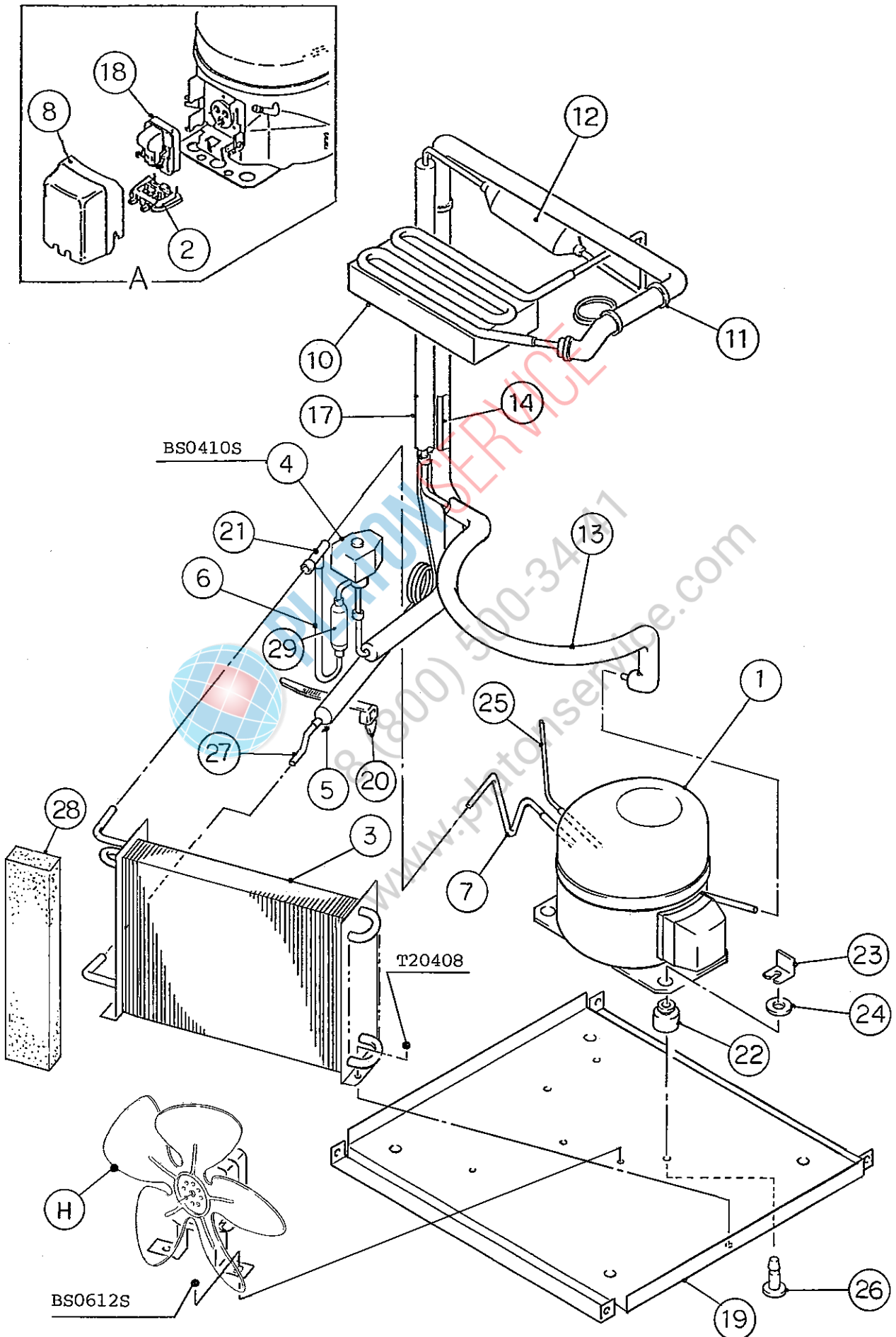

HE, GENERAL, RINNAI, OCEANIA, AUSTRALIA, HSP

MODEL : IM-25CLE, IM-25CLE-25 IM-30CLE, IM-30CLE-25 TITLE : B. REFRIGERATION ASSY							
INDEX NO.	DESCRIPTION	MATERIAL OR MODEL NUMBER	PART NUMBER	REQ'D NUMBER			
				J-1 K-0	K-1	K-2 A-05	A-1 B-0 C-0
H	FAN MOTOR ASSY	(S-9063)	3X2607A01	1	1	—	
		(S-9101)	3X1507A01			1	1
1	COMPRESSOR	TLS6F	450900-01	1	1	1	1
2	CORD RELIEF	103N1006	450899-01	1	1	1	1
3	CONDENSER - AIR COOLED	-	3X2569-01	1	1	—	
		-	2H4480-01			1	1
		-	2H5942-01				
4	HOT GAS SOLENOID VALVE	AMS-24B10HD-1	418866-02	1	1	1	1
5	DRIER	KC-7861	444792-01	1	1	—	
		DY-12QHD-2	445655-04			1	1
6	COPPER TUBE (A) - HOT GAS	COPPER	4X6701-01	1	1	1	1
			4Y0911-01				
7	COPPER TUBE (H)	COPPER	3X2596-01	1	1	1	1
			3X7275-01				
8	COVER	103N2010	450896-01	1	1	1	1
9	PROCESS TUBE (A)	COPPER	4H4351-01	1	1	x	
10	EVAPORATOR	(IM-25CLE) (IM-30CLE)	3H9020G02	1	1	1	1
	EVAPORATOR	(IM-25CLE-25) (IM-30CLE-25)	3H3881G01	1	1	1	1
11	TIE	CV-100	7920-0002	REQ'D	REQ'D	REQ'D	REQ'D
12	HEAT EXCHANGER	COPPER	4X3926G01	1	1	1	1
13	COPPER TUBE (L)	COPPER	3X2570G01	1	1	—	
		COPPER	3X3191G01			1	1
		COPPER	3X3191G02				
14	COPPER TUBE (B) - HOT GAS	COPPER	3X2595G01	1	1	1	1
		COPPER	3X2595G02				
15	SEAL (A)	PE	4H4359-03	1	1	—	
		PE	4H4359-05			x1	
16	AIR BOARD	G.S	4X6821-01	1	1	—	
17	INSULATION TUBE (A)	12 ID x 24 OD, L=420	3X2605-04	1	1	1	1
18	PTC STARTING DEVICE	103N0011	450901-01	1	1	1	1

HE, GENERAL, RINNAI, OCEANIA, AUSTRALIA, HSP

MODEL : IM-25CLE, IM-25CLE-25 IM-30CLE, IM-30CLE-25 TITLE : B. REFRIGERATION ASSY							
INDEX NO.	DESCRIPTION	MATERIAL OR MODEL NUMBER	PART NUMBER	REQ'D NUMBER			
				C-1 D-0	D-1	D-2 E-0	E-1 F-0 G-0
H	FAN MOTOR ASSY	-	-				
		(S-9101)	3X1507A01	1	1	1	1
1	COMPRESSOR	TLS6F	450900-01	1	1	1	1
2	CORD RELIEF	103N1006	450899-01	1	1	1	1
3	CONDENSER - AIR COOLED	-	-				
		-	2H4480-01	—			
		-	2H5942-01	1	1	1	1
4	HOT GAS SOLENOID VALVE	AMS-24B10HD-1	418866-02	1	1	1	1
5	DRIER	-	-				
		DY-12QHD-2	445655-04	1	1	1	1
6	COPPER TUBE (A) - HOT GAS	COPPER	4X6701-01				
			4Y0911-01	1	1	1	1
7	COPPER TUBE (H)	COPPER	3X2596-01	—			
			3X7275-01	1	1	1	1
8	COVER	103N2010	450896-01	1	1	1	1
9	-	-	-				
10	EVAPORATOR	(IM-25CLE) (IM-30CLE)	3H9020G02	1	1	1	1
	EVAPORATOR	(IM-25CLE-25) (IM-30CLE-25)	3H3881G01	1	1	1	1
11	TIE	CV-100	7920-0002	REQ'D	REQ'D	REQ'D	REQ'D
12	HEAT EXCHANGER	COPPER	4X3926G01	1	1	1	1
13	COPPER TUBE (L)	-	-				
		COPPER	3X3191G01	—			
		COPPER	3X3191G02	1	1	1	1
14	COPPER TUBE (B) - HOT GAS	COPPER	3X2595G01	—			
		COPPER	3X2595G02	1	1	1	1
15	-	-	-				
		-	-				
16	AIR BOARD	G.S	4X6821-01				
17	INSULATION TUBE (A)	12 ID x 24 OD, L=420	3X2605-04	1	1	1	1
18	PTC STARTING DEVICE	103N0011	450901-01	1	1	1	1

HE, GENERAL, RINNAI, OCEANIA, AUSTRALIA, HSP,GRAM,CHINA

MODEL : IM-25CLE, IM-25CLE-25 IM-30CLE, IM-30CLE-25 TITLE : B. REFRIGERATION ASSY							
INDEX NO.	DESCRIPTION	MATERIAL OR MODEL NUMBER	PART NUMBER	REQ'D NUMBER			
				G-1	H-1	H-2,U-0 V-0,A-01 L-0	
H	FAN MOTOR ASSY	(S-9101)	3X1507A01	1	1	1	
1	COMPRESSOR	TLS6F	450900-01	1	1	1	
2	CORD RELIEF	103N1006	450899-01	1	1	1	
3	CONDENSER - AIR COOLED	-	2H5942-01	1	1	1	
4	HOT GAS SOLENOID VALVE	AMS-24B10HD-1	418866-02	1	1	1	
5	DRIER	DY-12QHD-2	445655-04	1	1	1	
6	COPPER TUBE (A) - HOT GAS	COPPER	4Y0911-01	1	1	1	
7	COPPER TUBE (H)	COPPER	3X7275-01	1	1	1	
8	COVER	103N2010	450896-01	1	1	1	
9	-	-	-				
10	EVAPORATOR	(IM-25CLE) (IM-30CLE)	3H9020G02	1	1	1	
	EVAPORATOR	(IM-25CLE-25) (IM-30CLE-25)	3H3881G01	1	1	1	
11	TIE	CV-100	7920-0002	REQ'D	REQ'D	REQ'D	
12	HEAT EXCHANGER	(HE,GENERAL, RINNAI,OCEANIA, AUSTRALIA,HSP, CHINA)	4X3926G01	1	1	1	
		(GRAM)	4Y6122G01			1	
13	COPPER TUBE (L)	COPPER	3X3191G02	1	1	1	
14	COPPER TUBE (B) - HOT GAS	COPPER	3X2595G02	1	1	1	
15	-	-	-				
16	AIR BOARD	G.S	4X6821-01				
17	INSULATION TUBE (A)	12 ID x 24 OD, L=420	3X2605-04	1	1	1	
18	PTC STARTING DEVICE	103N0011	450901-01	1	1	1	
19	BASE	G.S	3X7277-01	1	1	-	
		G.S	3Y3672G01			1	
20	TIE	RT30SSF5	457167-01	1	1	1	
21	TEE	COPPER	420041-03	1	1	1	
22	RUBBER GROMMET	-	450897-01	4	4	4	
23	CLIP	-	452256-01	2	2	2	
24	WASHER	-	450894-01	2	2	2	
25	PROCESS TUBE (B)	COPPER	4X3379-01	1	1	1	

HE, GENERAL, RINNAI, OCEANIA, AUSTRALIA, HSP

MODEL : IM-25CLE, IM-25CLE-25 IM-30CLE, IM-30CLE-25 TITLE : B. REFRIGERATION ASSY							
INDEX NO.	DESCRIPTION	MATERIAL OR MODEL NUMBER	PART NUMBER	REQ'D NUMBER			
				J-1 K-0	K-1	K-2 A-05	A-1 B-0 C-0
19	BASE	G.S	3X2567-01	1	1	1	1
		G.S	3X7277-01				
20	TIE	RT30SSF5	457167-01	1	1	1	1
21	TEE	COPPER	420041-03	1	1	1	1
22	RUBBER GROMMET	-	450897-01	4	4	4	4
23	CLIP	-	452256-01	2	2	2	2
24	WASHER	-	450894-01	2	2	2	2
25	PROCESS TUBE (B)	COPPER	4X3379-01	1	1	1	1
26	STEEL PIN	-	452255-01	2	2	2	2
27	COPPER TUBE	COPPER	4Y0912-01				
28	SEAL(B)	PE	4Y0914-01				
29	STRAINER	COPPER	451772-01	1	1	1	1
30	COPPER TUBE	COPPER	4X6700-01	1	1	1	1

HE, GENERAL, RINNAI, OCEANIA, AUSTRALIA, HSP

MODEL : IM-25CLE, IM-25CLE-25 IM-30CLE, IM-30CLE-25 TITLE : B. REFRIGERATION ASSY							
INDEX NO.	DESCRIPTION	MATERIAL OR MODEL NUMBER	PART NUMBER	REQ'D NUMBER			
				C-1 D-0	D-1	D-2 E-0	E-1 F-0 G-0
19	BASE	G.S	3X2567-01	—			
		G.S	3X7277-01	1	1	1	1
20	TIE	RT30SSF5	457167-01	1	1	1	1
21	TEE	COPPER	420041-03	1	1	1	1
22	RUBBER GROMMET	-	450897-01	4	4	4	4
23	CLIP	-	452256-01	2	2	2	2
24	WASHER	-	450894-01	2	2	2	2
25	PROCESS TUBE (B)	COPPER	4X3379-01	1	1	1	1
26	STEEL PIN	-	452255-01	2	2	2	2
27	COPPER TUBE	COPPER	4Y0912-01	1	1	1	1
28	SEAL(B)	PE	4Y0914-01	1	1	1	1
29	STRAINER	COPPER	451772-01	1	1	1	1
30	COPPER TUBE	COPPER	4X6700-01	x			

IM-25CLE, -25
IM-30CLE, -25

C. ICEMAKING MECHANISM ASSY (A-05)
(J-1) (K-0) (K-1) (K-2)

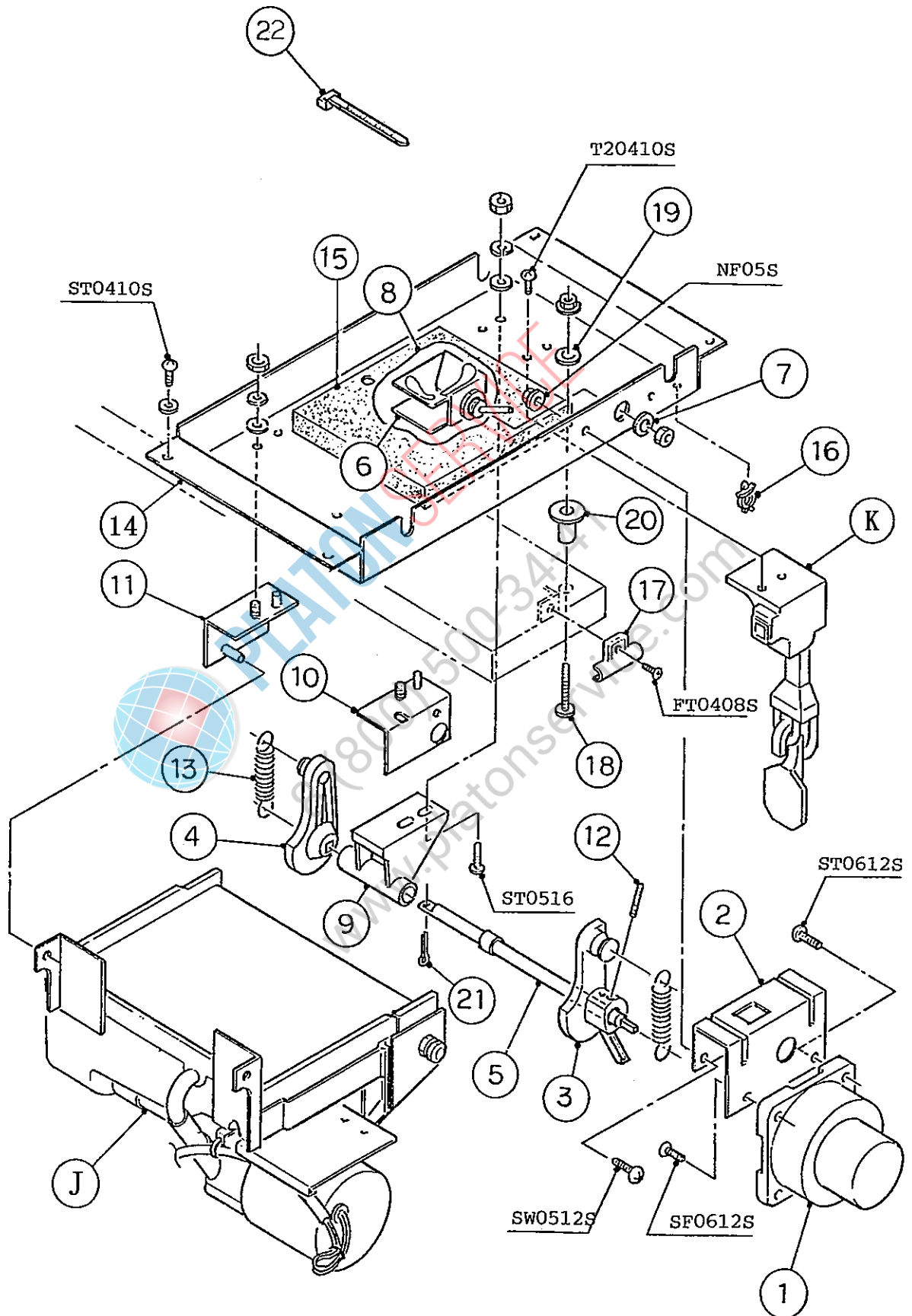

IM-25CLE, -25
IM-30CLE, -25

C. ICEMAKING MECHANISM ASSY

(E-1) and later
(D-0) (D-1) (D-2) (E-0)
(A-1) (B-0) (C-0) (C-1)

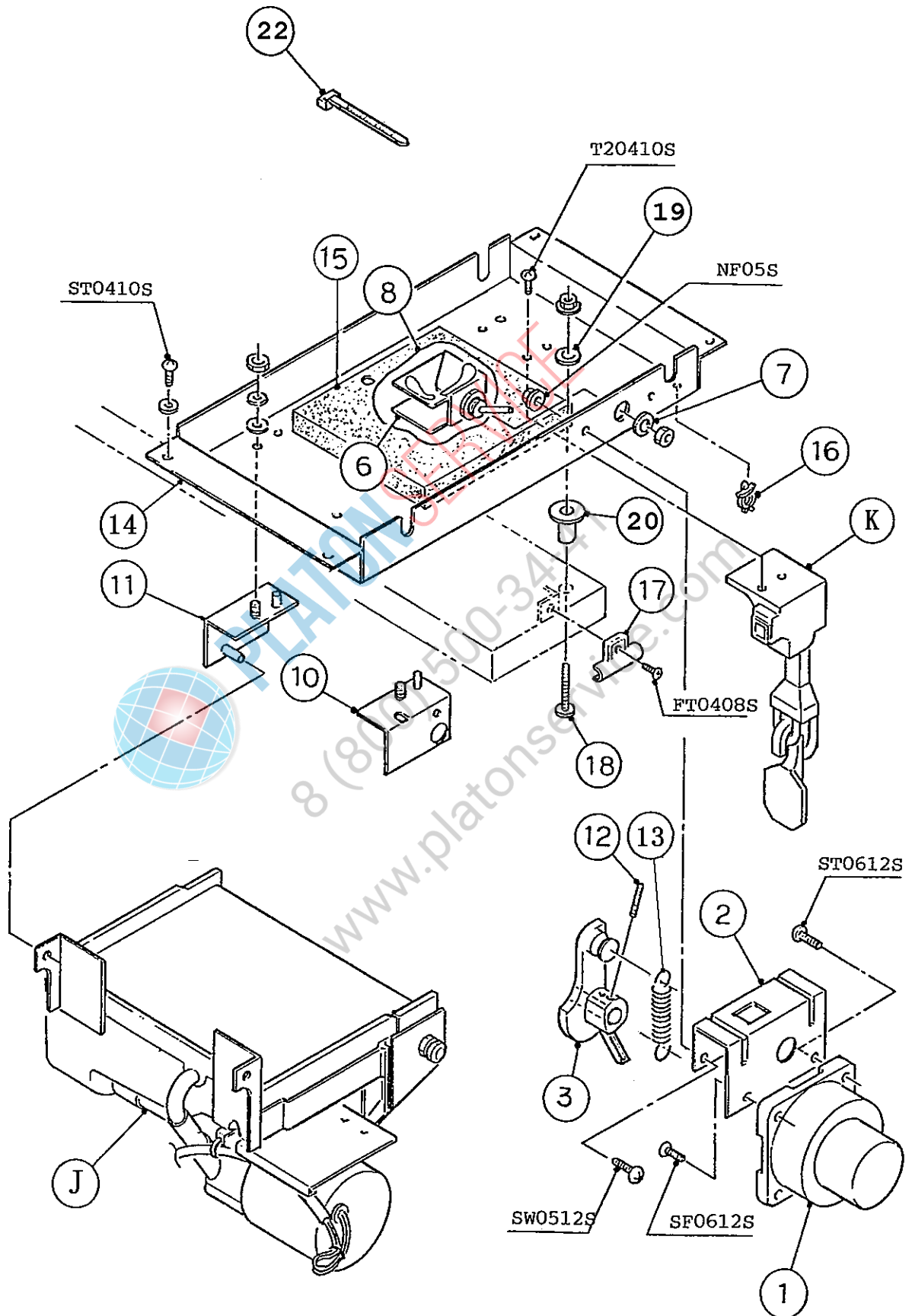

HE, GENERAL, RINNAI, OCEANIA, AUSTRALIA, HSP

MODEL : IM-25CLE, IM-25CLE-25 IM-30CLE, IM-30CLE-25 TITLE : C. ICEMAKING MECHANISM ASSY							
INDEX NO.	DESCRIPTION	MATERIAL OR MODEL NUMBER	PART NUMBER	REQ'D NUMBER			
				J-1 K-0	K-1	K-2 A-05	A-1 B-0 C-0
J	WATER PAN ASSY	(IM-25CLE)	2H0687A03	1	—		
		(IM-30CLE)	2H0687A05		1	1	1
	WATER PAN ASSY	(IM-25CLE-25) (IM-30CLE-25)	-	1	1	1	1
K	BIN CONTROL SWITCH ASSY	(S-0816)	3H1536A03	1	1	1	1
1	ACTUATOR MOTOR	SR486A43-12	457880-01	1	1	1	1
2	BRACKET - ACTUATOR MOTOR	G.S	3H1413-01	1	1	1	1
3	CAM (A)	AC	3X8002-01	1	1	1	1
4	CAM (B)	AC	3H2945-01	1	1	1	x
5	CAM SHAFT	S.S	4H5274G01	1	1	1	x
6	TOGGLE SWITCH	VAT4-71	431977-01	1	1	1	1
7	WASHER - TOGGLE SWITCH	S.S	406196-01	1	1	1	1
8	COVER - THERMISTOR	PE	408163-01	1	1	1	1
9	CAM SHAFT HOLDER	ABS	307256-01	1	1	1	x
10	BEARING(A)-WATER PAN	S.S	4H2652G02	1	1	1	1
11	BEARING(B)-WATER PAN	S.S	4H2653G02	1	1	1	1
12	SPRING PIN	S.S, 3x22	712S-0322	1	1	1	1
13	SPRING	S.S	4H1143-01	2	2	2	1
14	BRACKET - ICEMAKING MECHANISM	G.S	3H9591-01	1	1	1	—
		G.S	3X5201-01				1
15	INSULATION (D)	PE	4X4013-01	1	1	1	1
16	CLAMP	No. 2674	427902-02	1	1	1	1
17	HOLDER - THERMISTOR	PE	3H9642-01	1	1	1	1
18	SCREW - EVAPORATOR MOUNTING	(IM-25CLE) (IM-30CLE)	4H2593-01	3	3	3	3
	SCREW EVAPORATOR	(IM-25CLE-25) (IM-30CLE-25)	4Y4922M02	3	3	3	3
19	WASHER	AC	4H0777-01	3	3	3	3
20	SPACER	(IM-25CLE) (IM-30CLE)	4H0471-01	3	3	3	3
	SPACER	(IM-25CLE-25) (IM-30CLE-25)	4X5342-01	3	3	3	3

HE, GENERAL, RINNAI, OCEANIA, AUSTRALIA, HSP

MODEL : IM-25CLE, IM-25CLE-25 IM-30CLE, IM-30CLE-25 TITLE : C. ICEMAKING MECHANISM ASSY							
INDEX NO.	DESCRIPTION	MATERIAL OR MODEL NUMBER	PART NUMBER	REQ'D NUMBER			
				C-1 D-0	D-1	D-2 E-0	E-1 F-0 G-0
J	WATER PAN ASSY	(IM-25CLE)	-				
		(IM-30CLE)	2H0687A05	1	1	1	1
	WATER PAN ASSY	(IM-25CLE-25) (IM-30CLE-25)	-	1	1	1	1
K	BIN CONTROL SWITCH ASSY	(S-0816)	3H1536A03	1	1	1	1
1	ACTUATOR MOTOR	SR486A43-12	457880-01	1	1	1	1
2	BRACKET - ACTUATOR MOTOR	G.S	3H1413-01	1	1	1	1
3	CAM (A)	AC	3X8002-01	1	1	1	1
4	-	-	-				
5	-	-	-				
6	TOGGLE SWITCH	VAT4-71	431977-01	1	1	1	1
7	WASHER - TOGGLE SWITCH	S.S	406196-01	1	1	1	1
8	COVER - THERMISTOR	PE	408163-01	1	1	1	1
9	-	-	-				
10	BEARING(A)-WATER PAN	S.S	4H2652G02	1	1	1	1
11	BEARING(B)-WATER PAN	S.S	4H2653G02	1	1	1	1
12	SPRING PIN	S.S, 3x22	712S-0322	1	1	1	1
13	SPRING	S.S	4H1143-01	1	1	1	1
14	BRACKET - ICEMAKING MECHANISM	-	-				
		G.S	3X5201-01	1	1	1	1
15	INSULATION (D)	PE	4X4013-01	1	1	1	1
16	CLAMP	No. 2674	427902-02	1	1	1	1
17	HOLDER - THERMISTOR	PE	3H9642-01	1	1	1	1
18	SCREW - EVAPORATOR MOUNTING	(IM-25CLE)	4H2593-01	3	3	3	3
		(IM-30CLE)					
	SCREW EVAPORATOR	(IM-25CLE-25) (IM-30CLE-25)	4Y4922M02	3	3	3	3
19	WASHER	AC	4H0777-01	3	3	3	3
20	SPACER	(IM-25CLE)	4H0471-01	3	3	3	3
		(IM-30CLE)					
	SPACER	(IM-25CLE-25) (IM-30CLE-25)	4X5342-01	3	3	3	3

HE, GENERAL, RINNAI, OCEANIA, AUSTRALIA, HSP,GRAM,CHINA

MODEL : IM-25CLE, IM-25CLE-25 IM-30CLE, IM-30CLE-25 TITLE : C. ICEMAKING MECHANISM ASSY							
INDEX NO.	DESCRIPTION	MATERIAL OR MODEL NUMBER	PART NUMBER	REQ'D NUMBER			
				G-1	H-1	H-2,U-0 V-0,A-01 L-0	
J	WATER PAN ASSY	(IM-25CLE) (IM-30CLE)	2H0687A05	1	1	1	
	WATER PAN ASSY	(IM-25CLE-25) (IM-30CLE-25)	-	1	1	1	
K	BIN CONTROL SWITCH ASSY	(S-0816)	3H1536A03	1	1	1	
1	ACTUATOR MOTOR	SR486A43-12	457880-01	1	1	1	
2	BRACKET - ACTUATOR MOTOR	G.S	3H1413-01	1	1	1	
3	CAM (A)	AC	3X8002-01	1	1	1	
4	-	-	-				
5	-	-	-				
6	TOGGLE SWITCH	VAT4-71	431977-01	1	1	1	
7	WASHER - TOGGLE SWITCH	S.S	406196-01	1	1	1	
8	COVER - THERMISTOR	PE	408163-01	1	1	1	
9	-	-	-				
10	BEARING(A)-WATER PAN	S.S	4H2652G02	1	1	1	
11	BEARING(B)-WATER PAN	S.S	4H2653G02	1	1	1	
12	SPRING PIN	S.S, 3x22	712S-0322	1	1	1	
13	SPRING	S.S	4H1143-01	1	1	1	
14	BRACKET - ICEMAKING MECHANISM	G.S	3X5201-01	1	1	1	
15	INSULATION (D)	PE	4X4013-01	1	1	1	
16	CLAMP	No. 2674	427902-02	1	1	1	
17	HOLDER - THERMISTOR	PE	3H9642-01	1	1	1	
18	SCREW - EVAPORATOR MOUNTING	(IM-25CLE) (IM-30CLE)	4H2593-01	3	3	3	
	SCREW EVAPORATOR	(IM-25CLE-25) (IM-30CLE-25)	4Y4922M02	3	3	3	
19	WASHER	AC	4H0777-01	3	3	3	
20	SPACER	(IM-25CLE) (IM-30CLE)	4H0471-01	3	3	3	
	SPACER	(IM-25CLE-25) (IM-30CLE-25)	4X5342-01	3	3	3	
21	-	-	-				
22	TIE	CV-100	7920-0002	1	1	1	

IM-25CLE, -25
IM-30CLE, -25

D. CONTROL BOX ASSY

(E-0)
(C-1) (D-0) (D-1) (D-2)
(A-05) (A-1) (B-0) (C-0)
(J-1) (K-0) (K-1) (K-2)

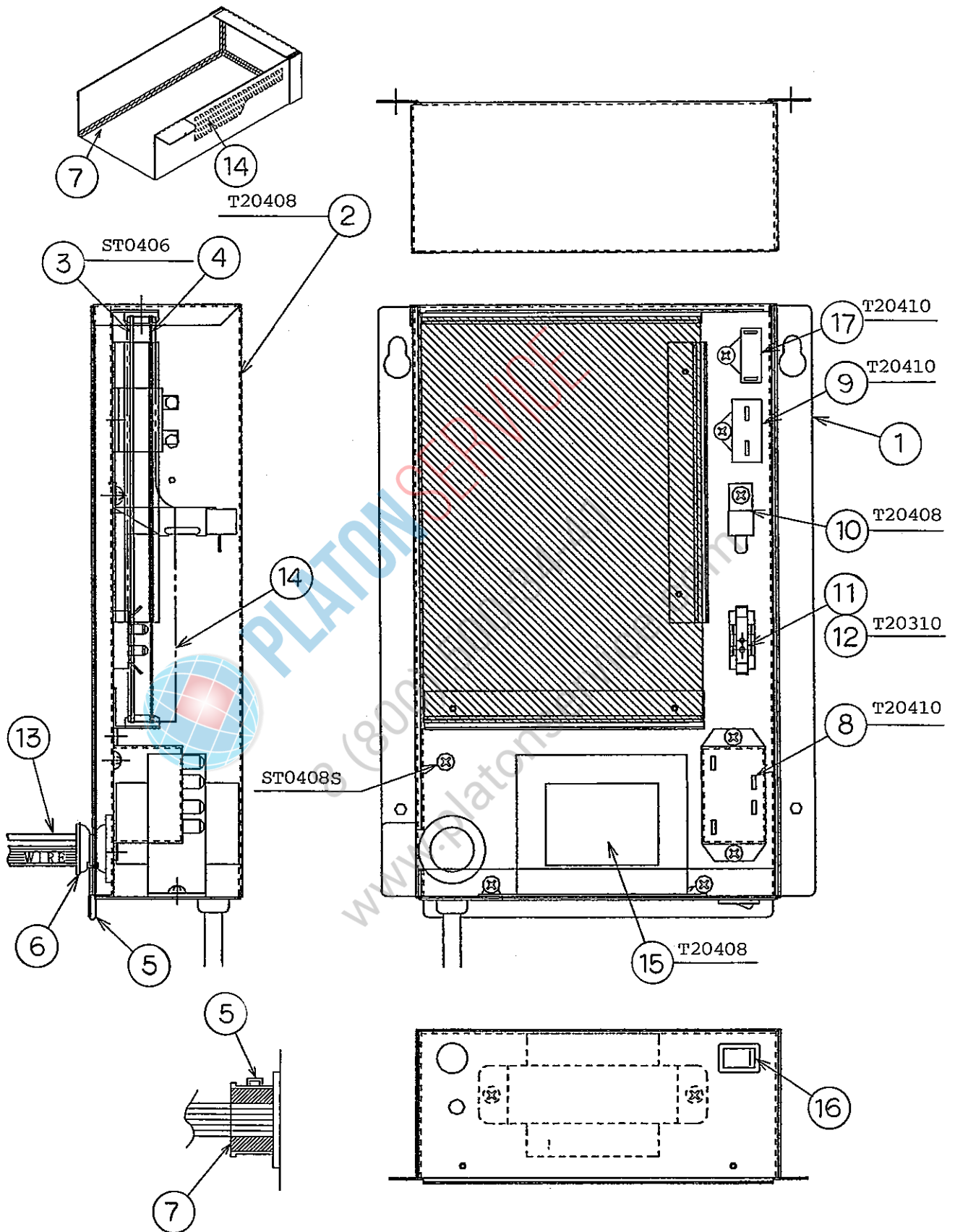

IM-25CLE, -25
IM-30CLE, -25

D. CONTROL BOX ASSY

(E-1) and later

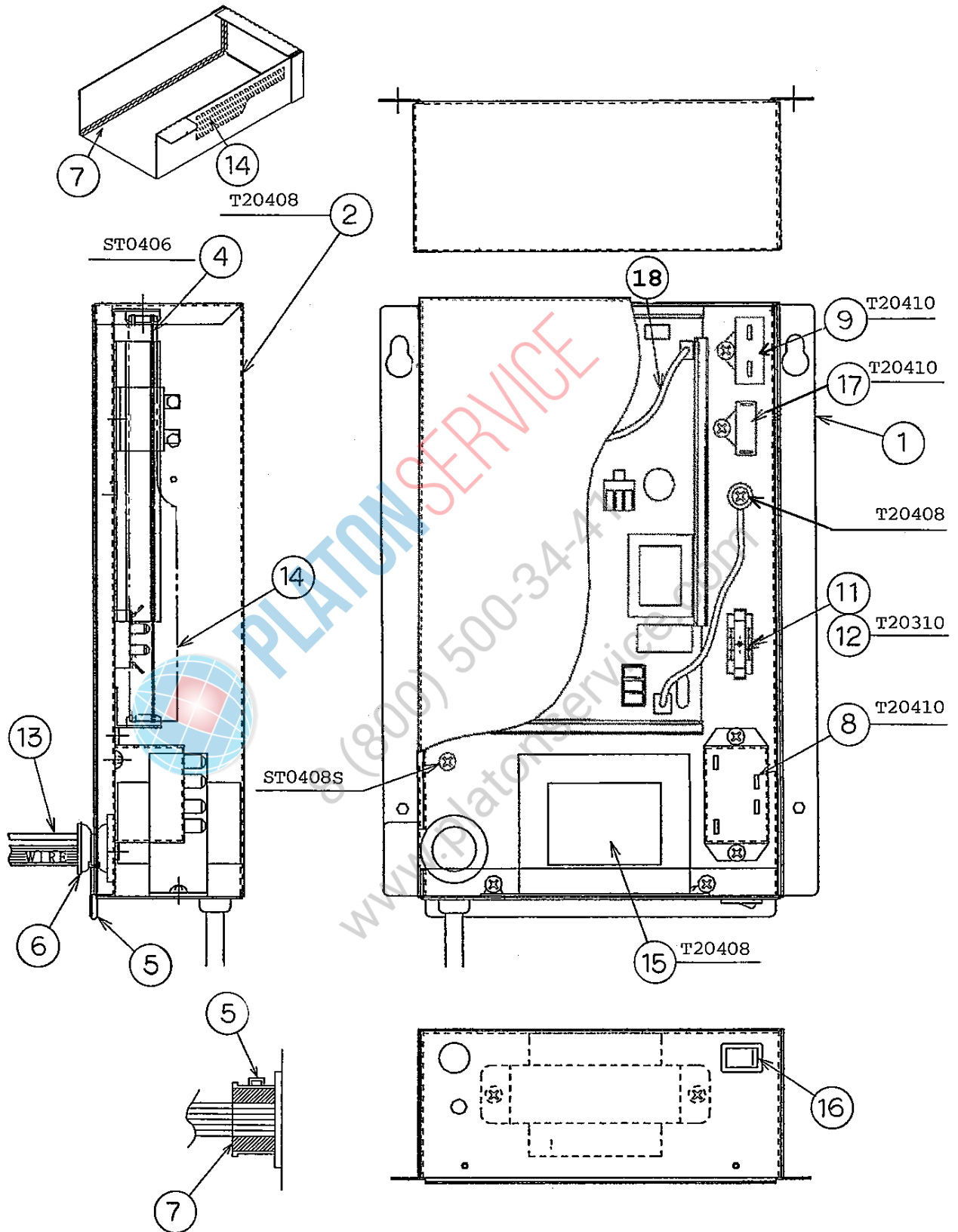

HE, GENERAL, RINNAI, OCEANIA, AUSTRALIA, HSP

MODEL : IM-25CLE, IM-25CLE-25 IM-30CLE, IM-30CLE-25 TITLE : D. CONTROL BOX ASSY							
INDEX NO.	DESCRIPTION	MATERIAL OR MODEL NUMBER	PART NUMBER	REQ'D NUMBER			
				J-1 K-0	K-1	K-2 A-05	A-1 B-0 C-0
1	CONTROL BOX	G.S	3X2636G01	1	1	1	1
		G.S	3X2636G02				
		G.S	3X2636G03				
2	CONTROL BOX COVER	G.S	3X2578-01	1	1	1	1
3	SHIELD PLATE	G.S	4H2594-01	1	1	1	1
4	CONTROLLER BOARD	H2AA136C10	436572-10	1	1	1	1
		H2AE024C18	462975-18				
5	NYLON TIE	PRT1.5S	427466-01	1	1	1	1
6	GROMMET	NBR	4H2568-01	1	1	1	1
7	SEAL TAPE	w8 x t3.2	2H3977-13	1	1	1	1
		w8 x t3.2	2H6749-08				
8	POWER RELAY	G7L-1A-TUB	449000-01	1	1	1	1
9	CAPACITOR - ACTUATOR MOTOR	UJ25B804UXF	456262-01	1	1	1	1
10	SURGE ABSORBER	-	436573-02	1	1	1	1
11	FUSE	5A	451924-01	1	1	1	1
12	FUSE HOLDER	445710	451925-01	1	1	1	1
		CFH15	4Y2547-01				
13	THERMISTOR	NBFC-36-AH1-1	462976-01	1	1	1	1
14	CUSHION	PE	4H2718-01	1	1	1	1
15	TRANSFORMER	230V/100V	450104-01	1	1	1	1
16	ROCKER SWITCH	H8600VB	460681-01	1	1	1	1
17	CAPACITOR - PUMP MOTOR	UJ20B105UWF	457885-01		1	1	1

HE, GENERAL, RINNAI, OCEANIA, AUSTRALIA, HSP

MODEL : IM-25CLE, IM-25CLE-25 IM-30CLE, IM-30CLE-25 TITLE : D. CONTROL BOX ASSY							
INDEX NO.	DESCRIPTION	MATERIAL OR MODEL NUMBER	PART NUMBER	REQ'D NUMBER			
				C-1 D-0	D-1	D-2 E-0	E-1 F-0 G-0
1	CONTROL BOX	G.S	3X2636G01	1	1	—	
		G.S	3X2636G02			1	1
		G.S	3X2636G03				
2	CONTROL BOX COVER	G.S	3X2578-01	1	1	1	1
3	SHIELD PLATE	G.S	4H2594-01	1	1	1	×
4	CONTROLLER BOARD	H2AA136C10	436572-10	1	1	1	—
		H2AE024C18	462975-18				1
5	NYLON TIE	PRT1.5S	427466-01	1	1	1	1
6	GROMMET	NBR	4H2568-01	1	1	1	1
7	SEAL TAPE	w8 x t3.2	2H3977-13	1	1	1	—
		w8 x t3.2	2H6749-08				1
8	POWER RELAY	G7L-1A-TUB	449000-01	1	1	1	1
9	CAPACITOR - ACTUATOR MOTOR	UJ25B804UXF	456262-01	1	1	1	1
10	SURGE ABSORBER	-	436573-02	1	1	1	×
11	FUSE	5A	451924-01	1	1	1	1
12	FUSE HOLDER	445710	451925-01	1	1	—	
		CFH15	4Y2547-01			1	1
13	THERMISTOR	NBFC-36-AH1-1	462976-01	1	1	1	1
14	CUSHION	PE	4H2718-01	1	1	1	1
15	TRANSFORMER	230V/100V	450104-01	1	1	1	1
16	ROCKER SWITCH	H8600VB	460681-01	1	1	1	1
17	CAPACITOR - PUMP MOTOR	UJ20B105UWF	457885-01	1	1	1	1
18	THERMISTOR-AMBIENT TEMP	182-103-86742	462977-02				1

IM-25CLE, -25
IM-30CLE, -25

E. DOOR ASSY

(C-1) (D-0)
(A-05)(A-1) (B-0) (C-0)
(J-1) (K-0) (K-1) (K-2)

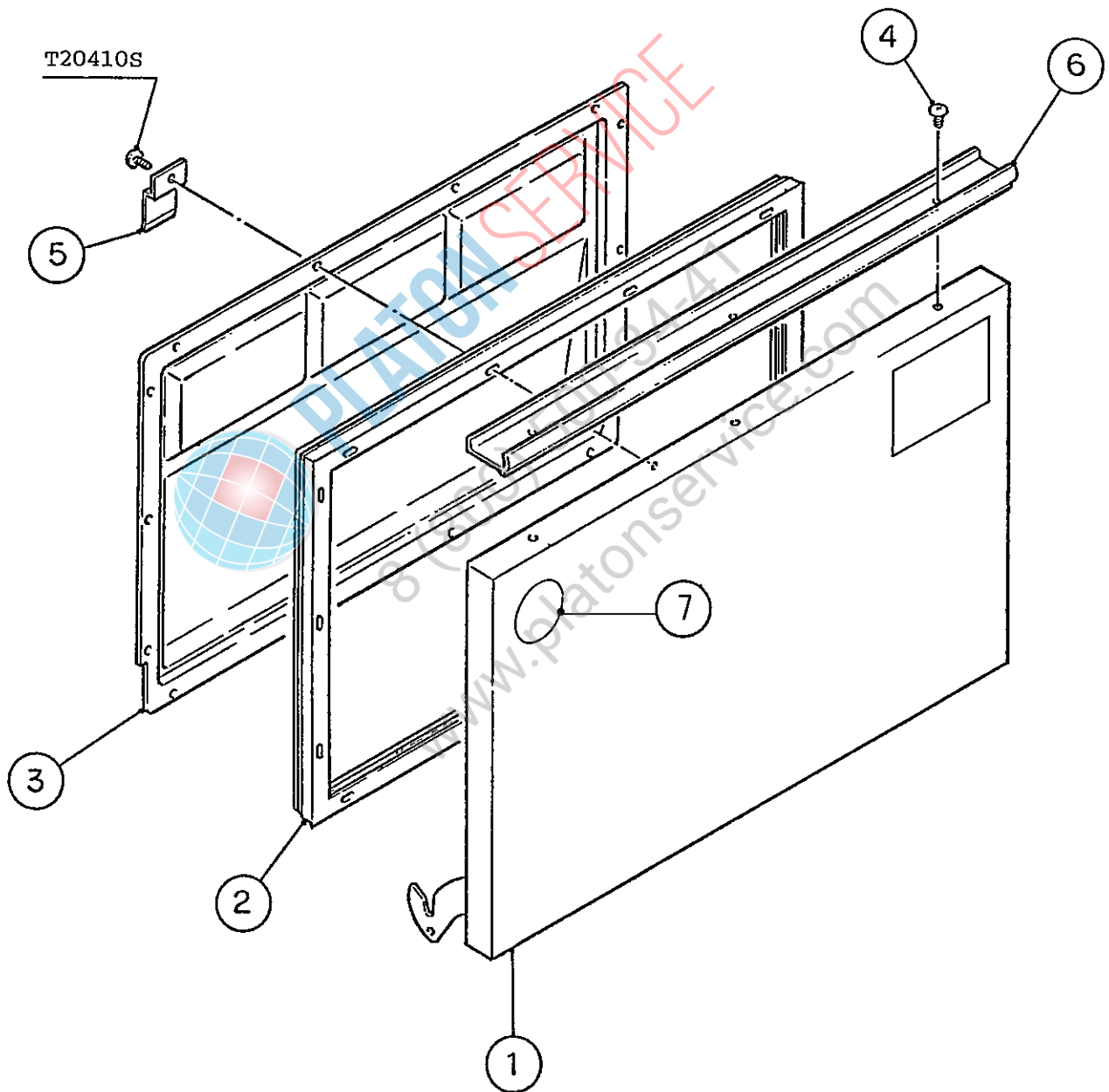

IM-25CLE, -25
IM-30CLE, -25

E. DOOR ASSY

(F-0) (G-0) (G-1)
(D-1) (D-2) (E-0) (E-1)

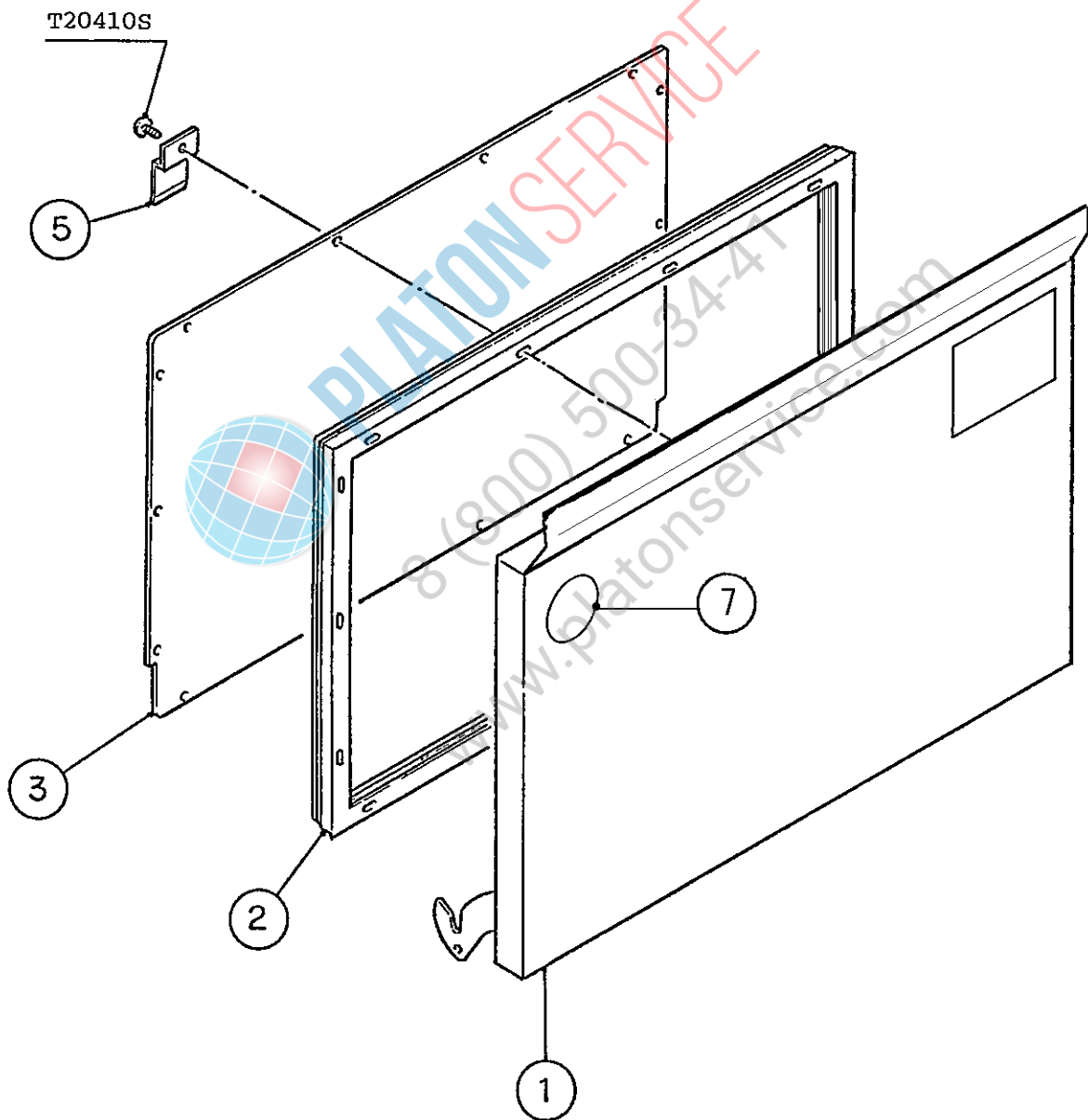

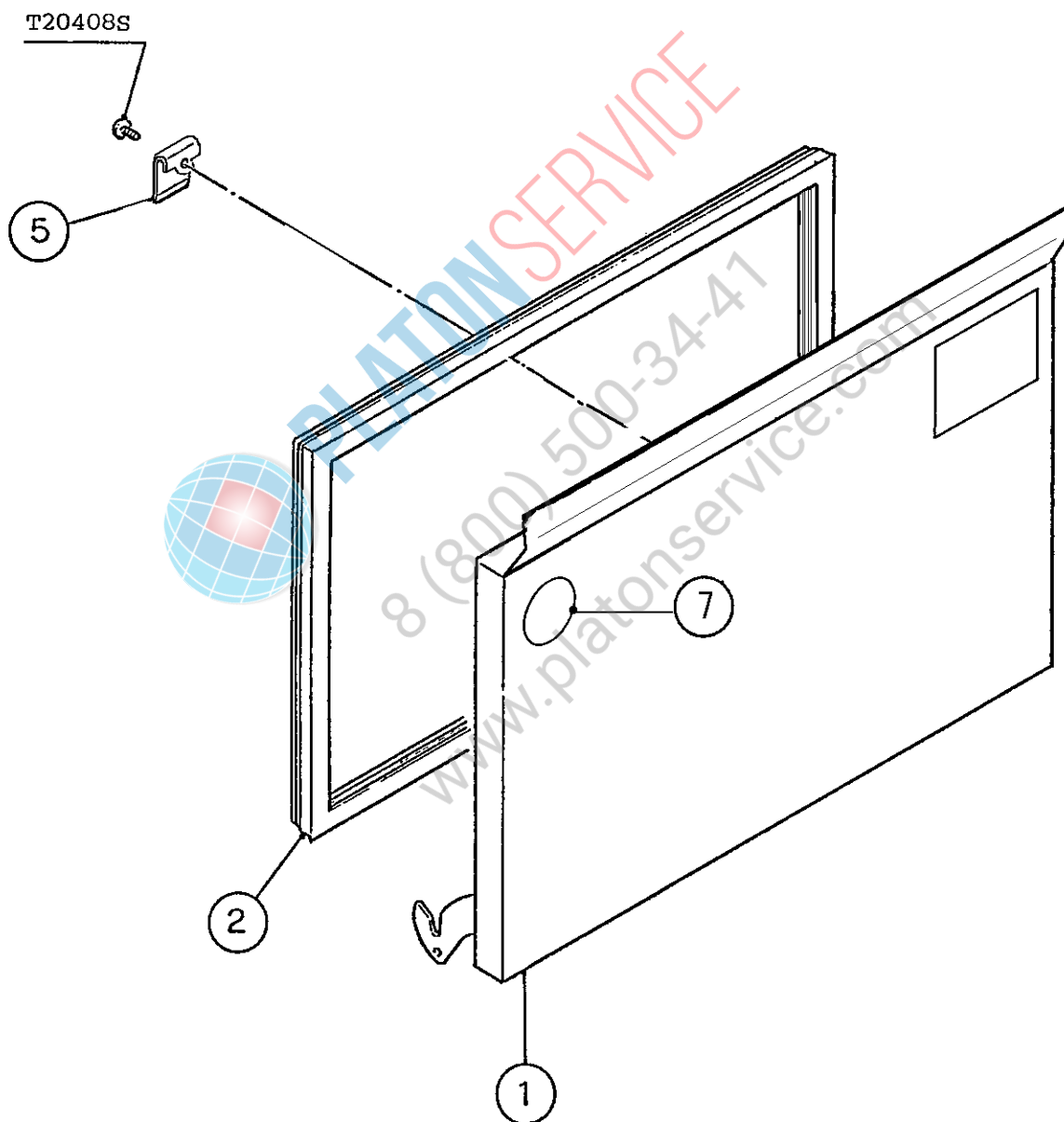

IM-25CLE, -25
IM-30CLE, -25

G. LABEL LOCATION

(E-0) (E-1) and later
(C-1) (D-0) (D-1) (D-2)
(A-05)(A-1) (B-0) (C-0)
(J-1) (K-0) (K-1) (K-2)

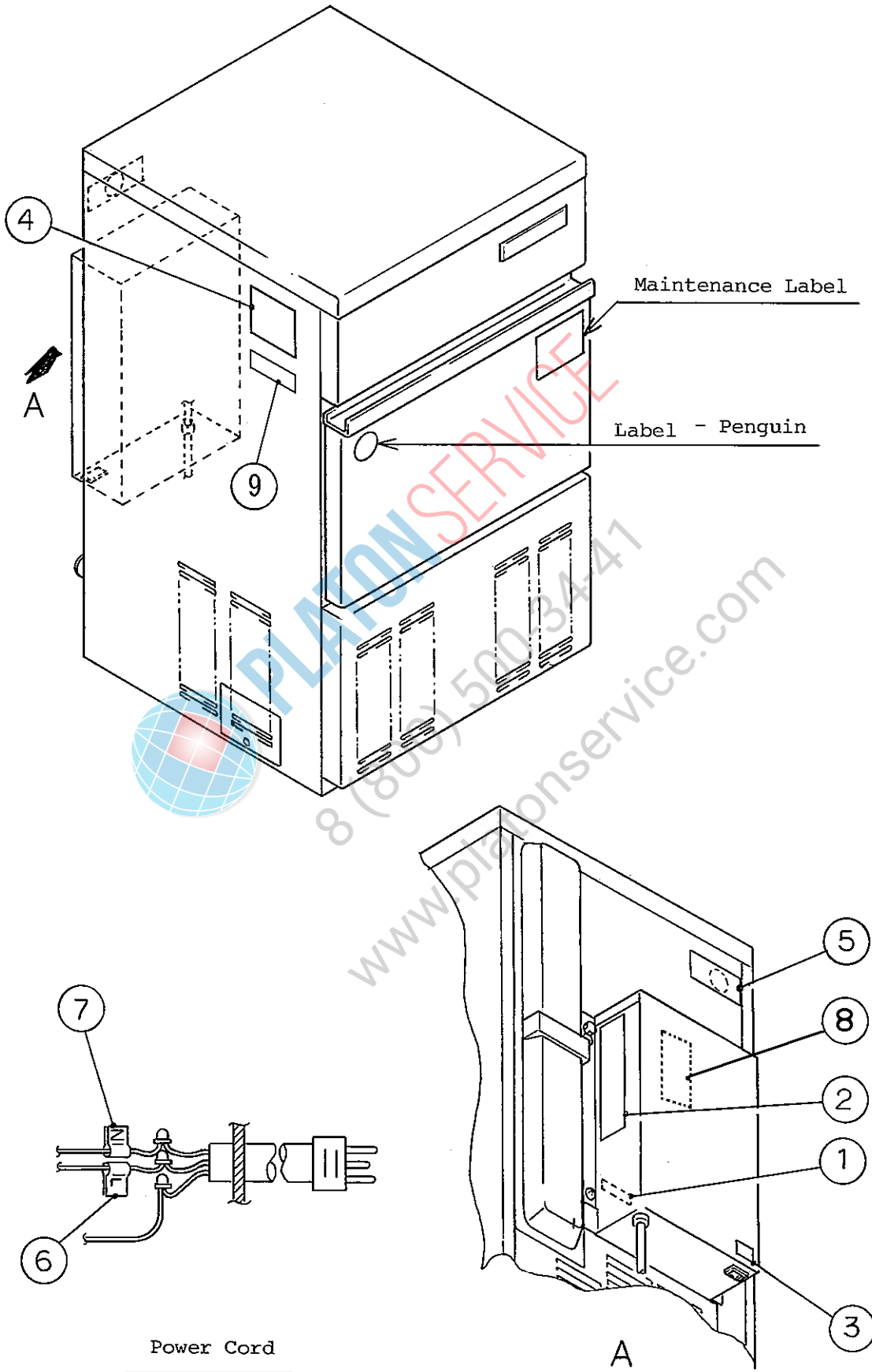

IM-25CLE, -25
IM-30CLE, -25

H. FAN MOTOR ASSY

(E-0) (E-1) and later
(C-1) (D-0) (D-1) (D-2)
(A-05)(A-1) (B-0) (C-0)
(J-1) (K-0) (K-1) (K-2)

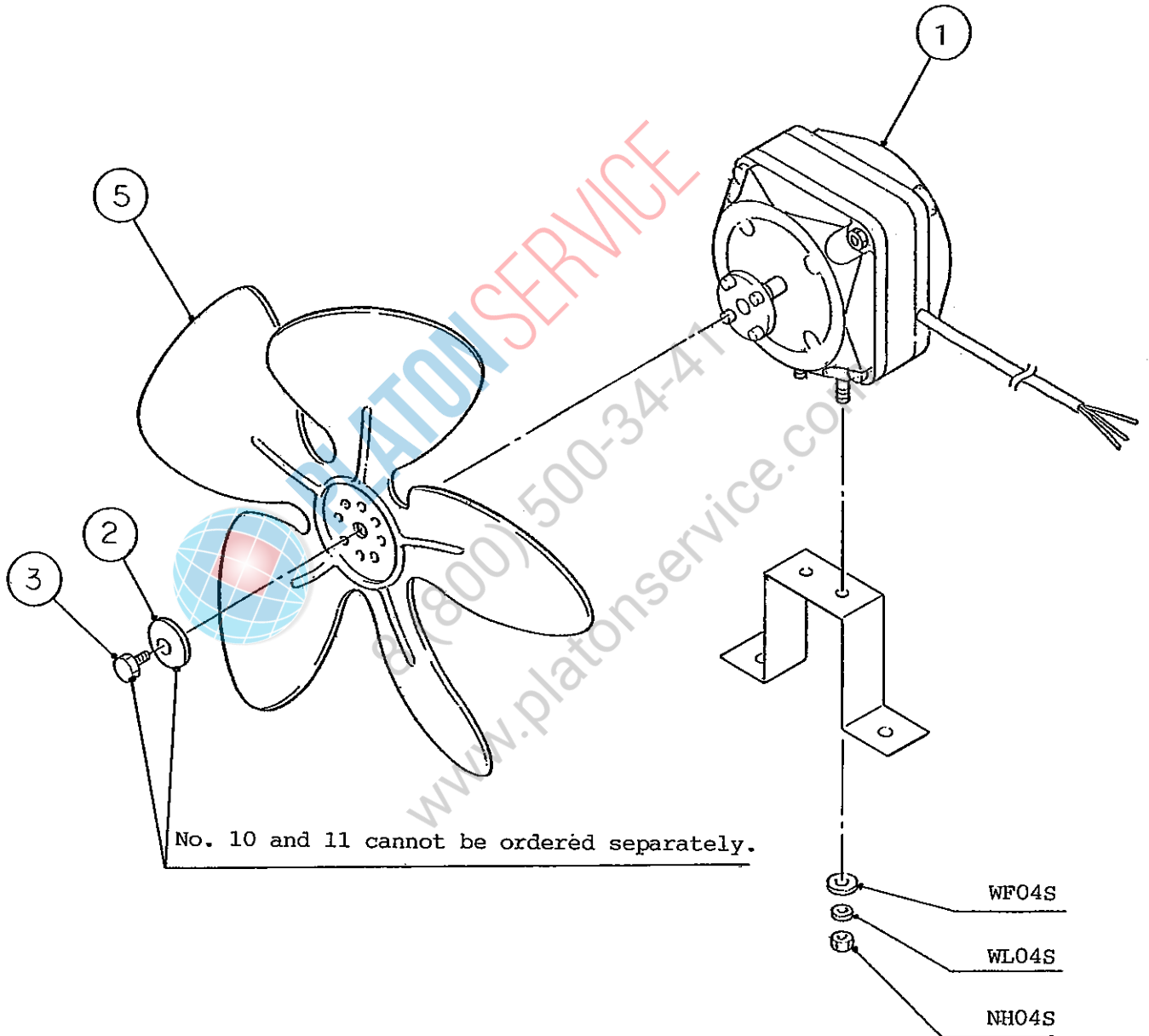

IM-25CLE, -25
IM-30CLE, -25

J. WATER PAN ASSY

(E-0) (E-1) and later
(C-1) (D-0) (D-1) (D-2)
(A-05)(A-1) (B-0) (C-0)
(J-1) (K-0) (K-1) (K-2)

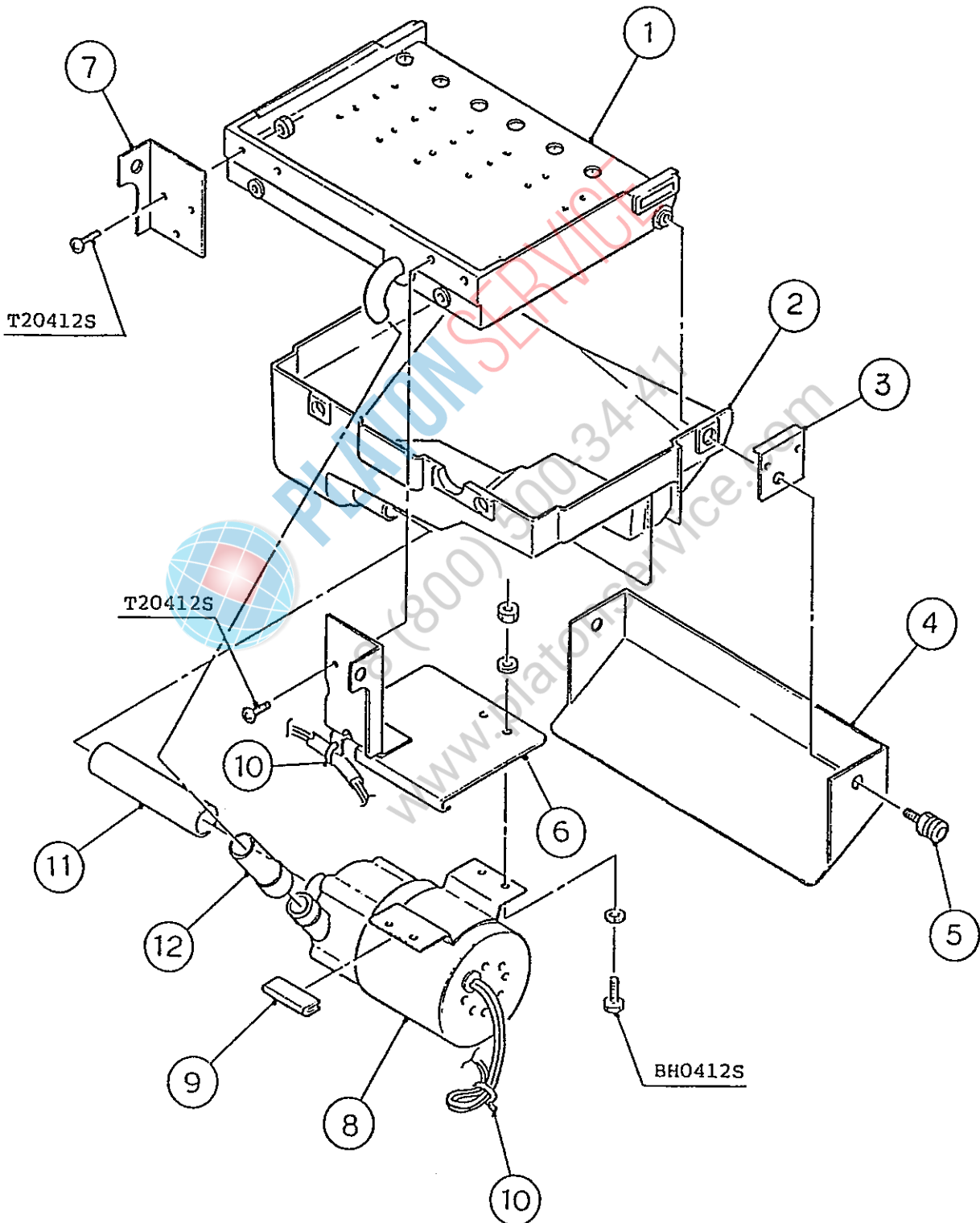

IM-25CLE, -25
IM-30CLE, -25

K. BIN CONTROL SWITCH ASSY

(E-0) (E-1) and later
(C-1) (D-0) (D-1) (D-2)
(A-05)(A-1) (B-0) (C-0)
(J-1) (K-0) (K-1) (K-2)

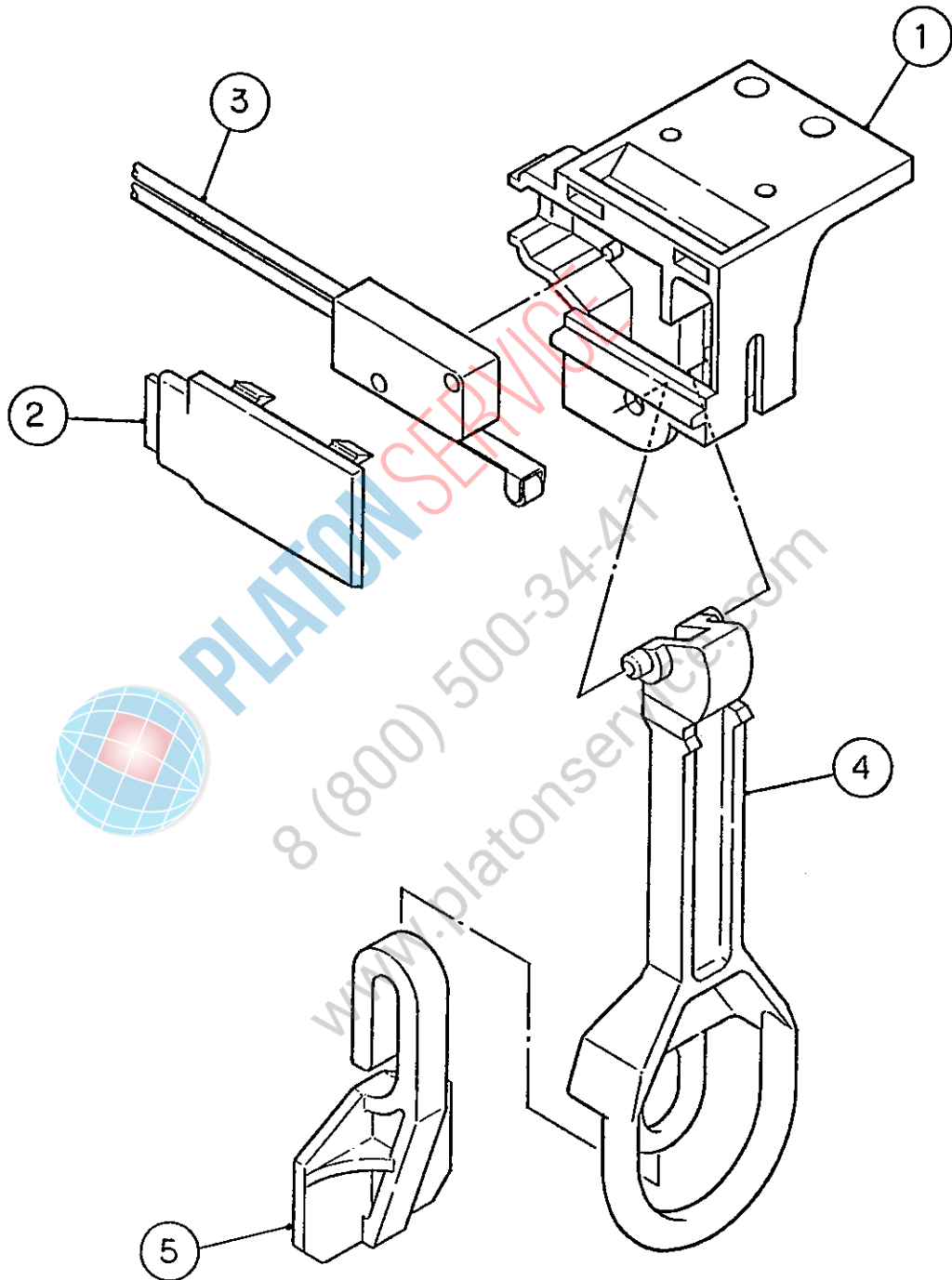

IM-25CLE, -25
IM-30CLE, -25

L. ACCESSORIES

(E-0) (E-1) and later
(C-1) (D-0) (D-1) (D-2)
(A-05)(A-1) (B-0) (C-0)
(J-1) (K-0) (K-1) (K-2)

